



basic education

Department:
Basic Education
REPUBLIC OF SOUTH AFRICA

SENIOR CERTIFICATE EXAMINATIONS/ NATIONAL SENIOR CERTIFICATE EXAMINATIONS

ENGINEERING GRAPHICS AND DESIGN P2

2021

MARKING GUIDELINES

MARKS: 100

These marking guidelines consist of 7 pages.

ANSWERS		
1	REAR DERAILLEUR ASSEMBLY	1
2	SPEED STREET	1
3	3	1
4	MAFIKA	1
5	VBJW031	1
6	SECTIONAL RIGHT VIEW	2
7	<i>See below</i>	1
8	3	1
9	B: R5 C: 16 D: 20 E: 98	4
10	135°	1
11	17	1
12	KNURLING	1
13	ACROSS FLATS	1
14	REVOLVED SECTION	1
15	<i>See below</i>	3
16	ALIGNED SECTION	1
17	1.64	2
18	<i>See below</i>	3
19		3
TOTAL		30

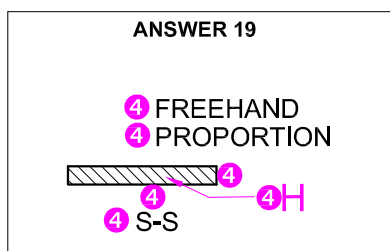
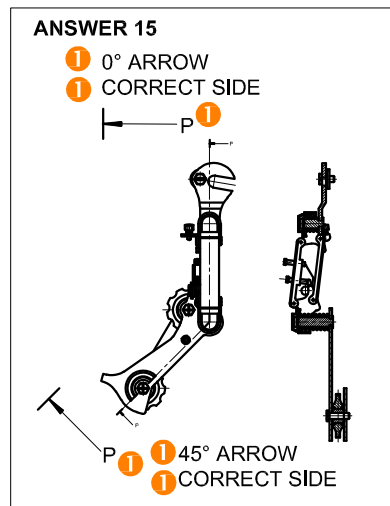
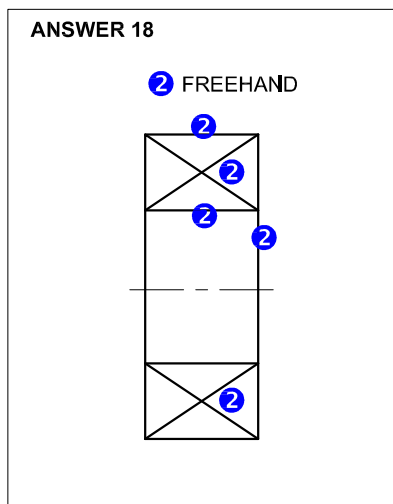
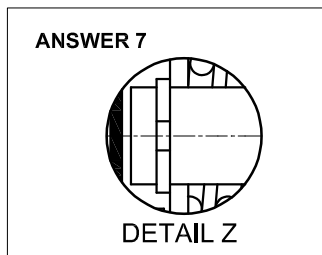

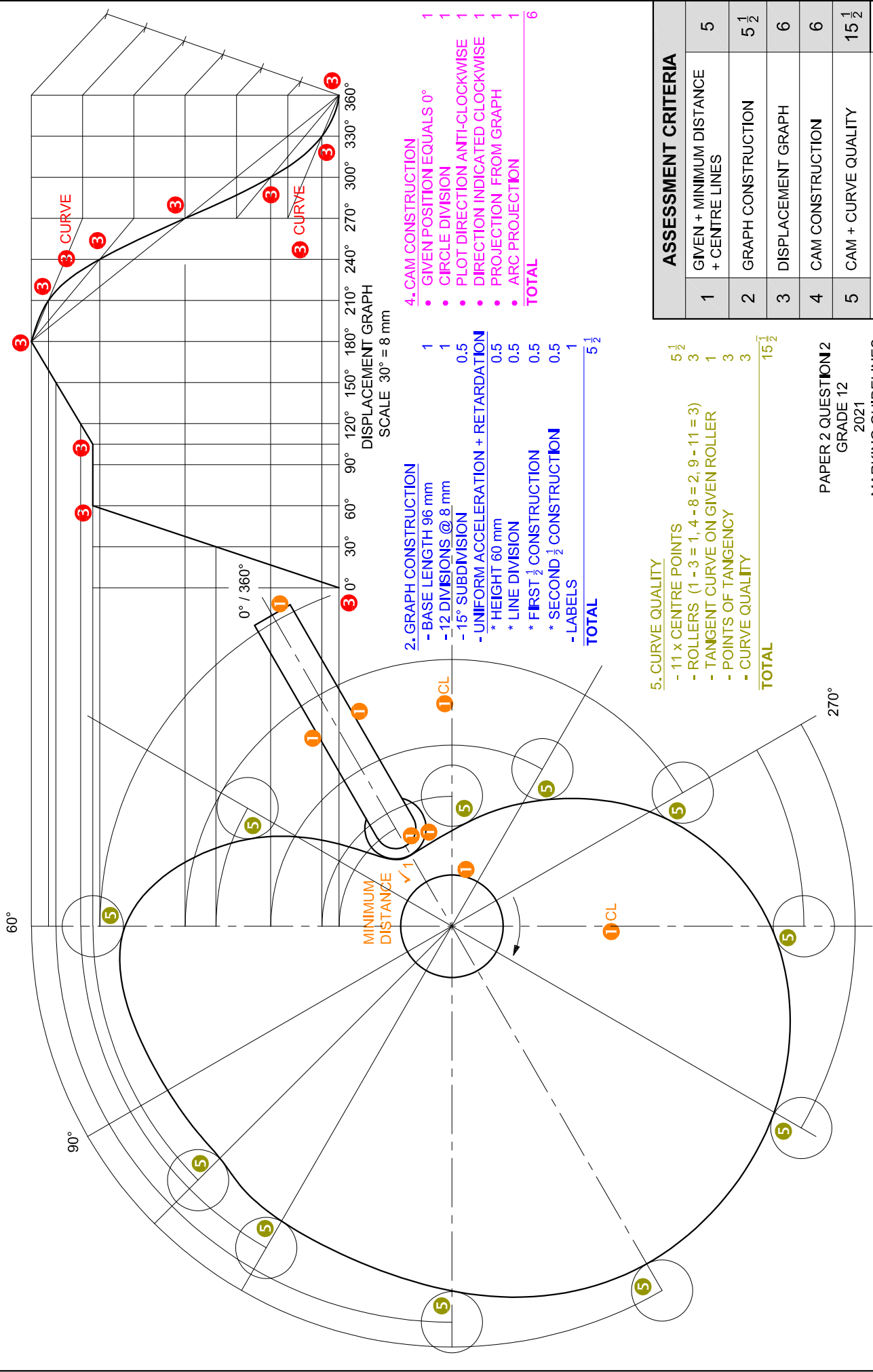

2. GRAPH CONSTRUCTION
 - BASE LENGTH 96 mm
 - 12 DIVISIONS @ 8 mm
 - 15° SUBDIVISION
 - UNIFORM ACCELERATION + RETARDATION
 * HEIGHT 60 mm
 * LINE DIVISION
 * FIRST 1/2 CONSTRUCTION
 * SECOND 1/2 CONSTRUCTION
 - LABELS
TOTAL 5 1/2

4. CAM CONSTRUCTION
 • GIVEN POSITION EQUALS 0° 1
 • CIRCLE DIVISION 1
 • PLOT DIRECTION ANTI-CLOCKWISE 1
 • DIRECTION INDICATED CLOCKWISE 1
 • PROJECTION FROM GRAPH 1
 • ARC PROJECTION 1
TOTAL 6

5. CURVE QUALITY
 - 11 x CENTRE POINTS 5 1/2
 - ROLLERS (1 - 3 = 1, 4 - 8 = 2, 9 - 11 = 3) 3
 - TANGENT CURVE ON GIVEN ROLLER 1
 - POINTS OF TANGENCY 3
 - CURVE QUALITY 3
TOTAL 15 1/2

ASSESSMENT CRITERIA	
1	GIVEN + MINIMUM DISTANCE + CENTRE LINES
2	GRAPH CONSTRUCTION
3	DISPLACEMENT GRAPH
4	CAM CONSTRUCTION
5	CAM + CURVE QUALITY
TOTAL	

PAPER 2 QUESTION 2
 GRADE 12
 2021
 MARKING GUIDELINES

1	5
2	5 1/2
3	6
4	6
5	15 1/2
TOTAL	
38	

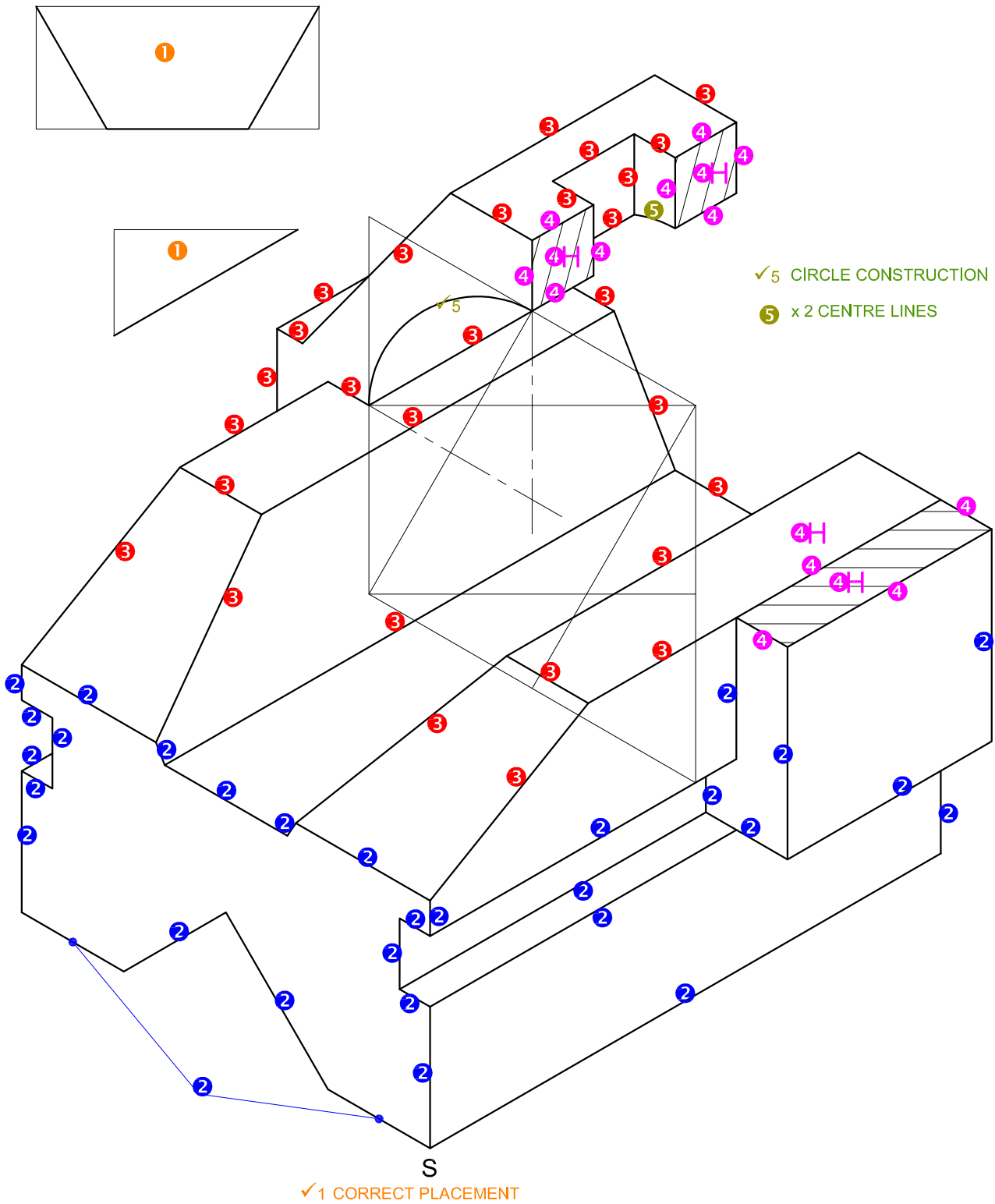

PAPER 2 QUESTION 3
GRADE 12
2021
MARKING GUIDELINES

ASSESSMENT CRITERIA		
1	AUX. VIEW + PLACING	2
2	LOWER PORTION	15
3	UPPER PORTION	14
4	SECTION	8
5	ISO CIRCLES + CIRCLE CONSTR' + CENTRE LINES	3
TOTAL		42

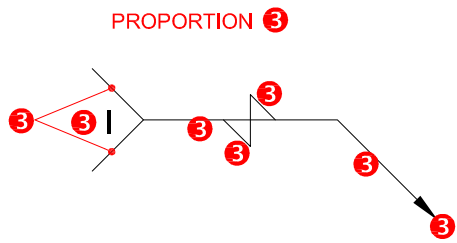

RIGHT VIEW		
		POSSIBLE
1	SHAFT + BUSH	1 1/2
2	CYLINDER + BRACKET + HOOK	4
3	M44 NUT + GUIDE	6
SUBTOTAL		11 1/2

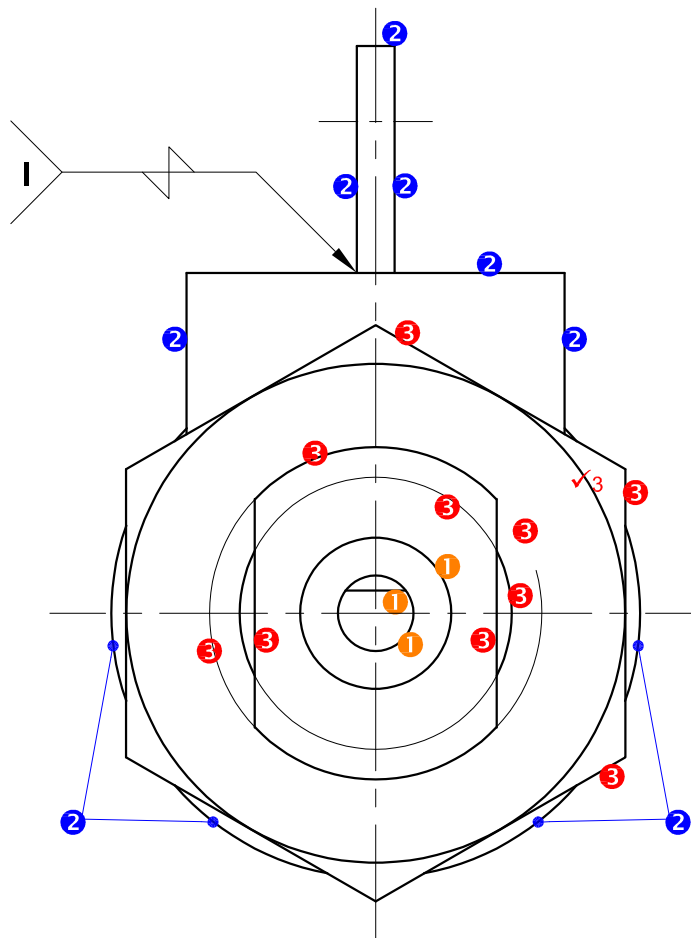

PAPER 2 QUESTION 4
 GRADE 12
 2021
 MARKING GUIDELINE

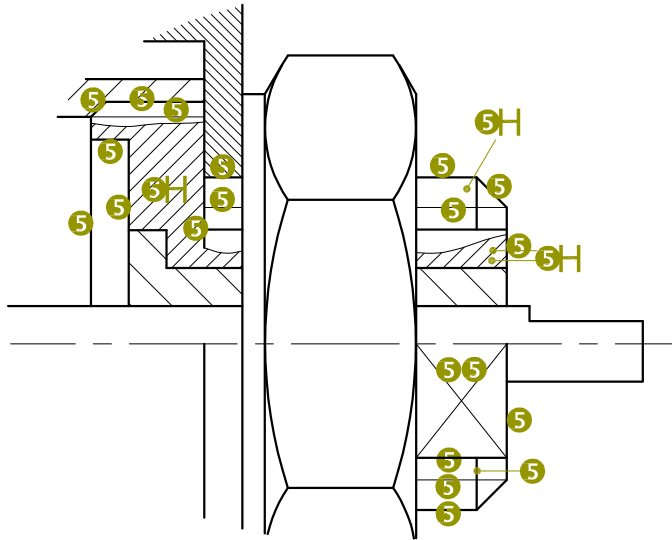

HALF-SECTIONAL FRONT VIEW		
1	CYLINDER	12
2	RUBBER SEAL	2 1/2
3	PLUNGER	5
4	BUSH	2 1/2
5	GUIDE	11 1/2
6	BRACKET + HOOK	6
7	M44 NUT + WASHER	6 1/2
SUBTOTAL		46

ALTERNATIVE ANSWER WITH A PART SECTION

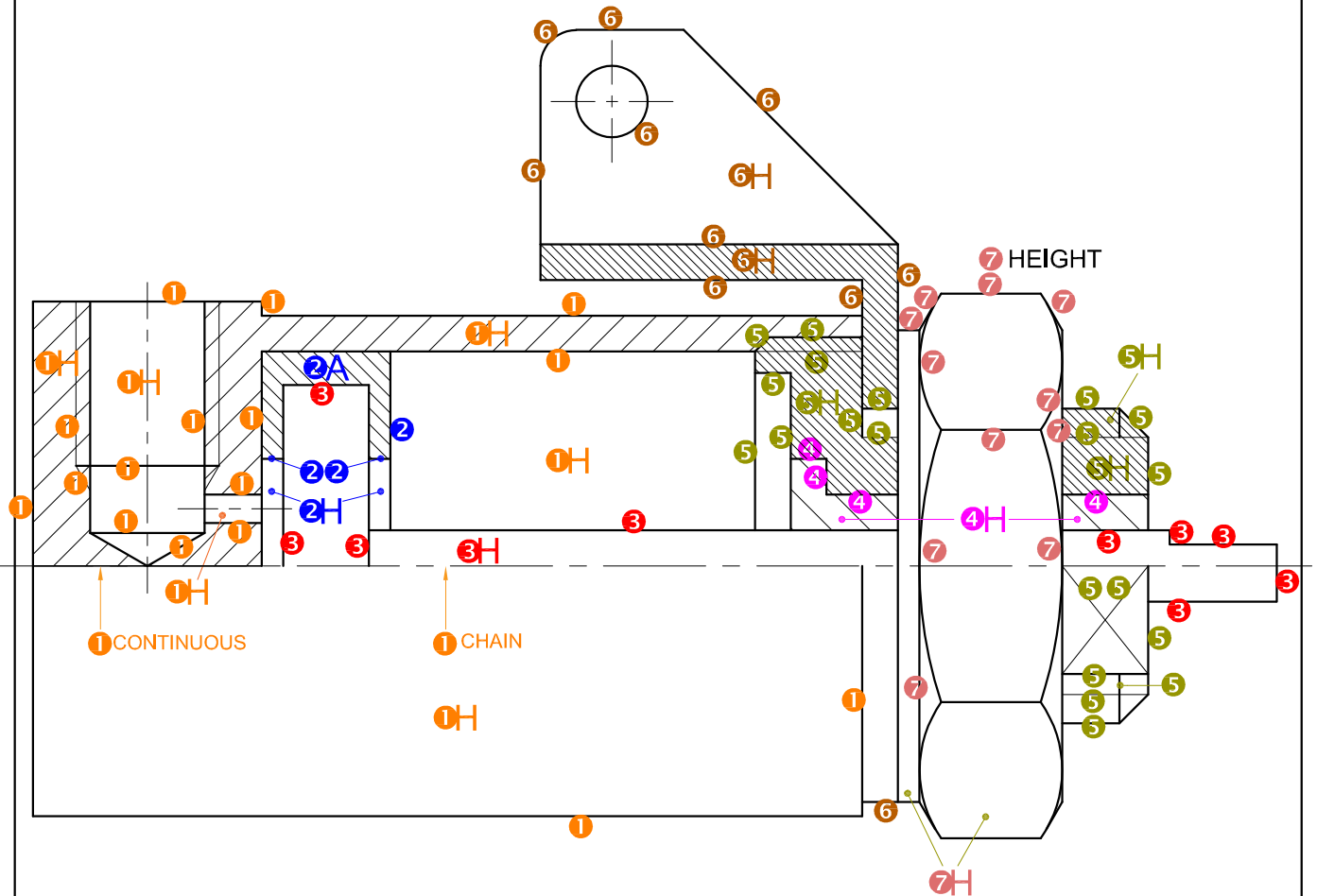

PAPER 2 QUESTION 4
 GRADE 12
 2021
 MARKING GUIDELINE

1. CENTRE LINE MARK ALLOCATION
 SANS COMPLIANT (LINE TYPE) 1
 11 CENTRE LINES (1 - 2 = 0, 3 - 5 = 1, 6 - 7 = 2) 2
TOTAL 3

2. ASSEMBLY
 1 MARK FOR EVERY
 COMPONENT CORRECTLY
 ASSEMBLED (9 PARTS -1) = 8

TOP VIEW		
1	CYLINDER	5 1/2
2	BRACKET + HOOK	3 1/2
3	GUIDE + SHAFT	4 1/2
	M44 NUT + WASHER	4
SUBTOTAL		17 1/2
GENERAL		
1	CENTRE LINES	3
2	ASSEMBLY	8
3	WELDING SYMBOL	4
SUBTOTAL		15

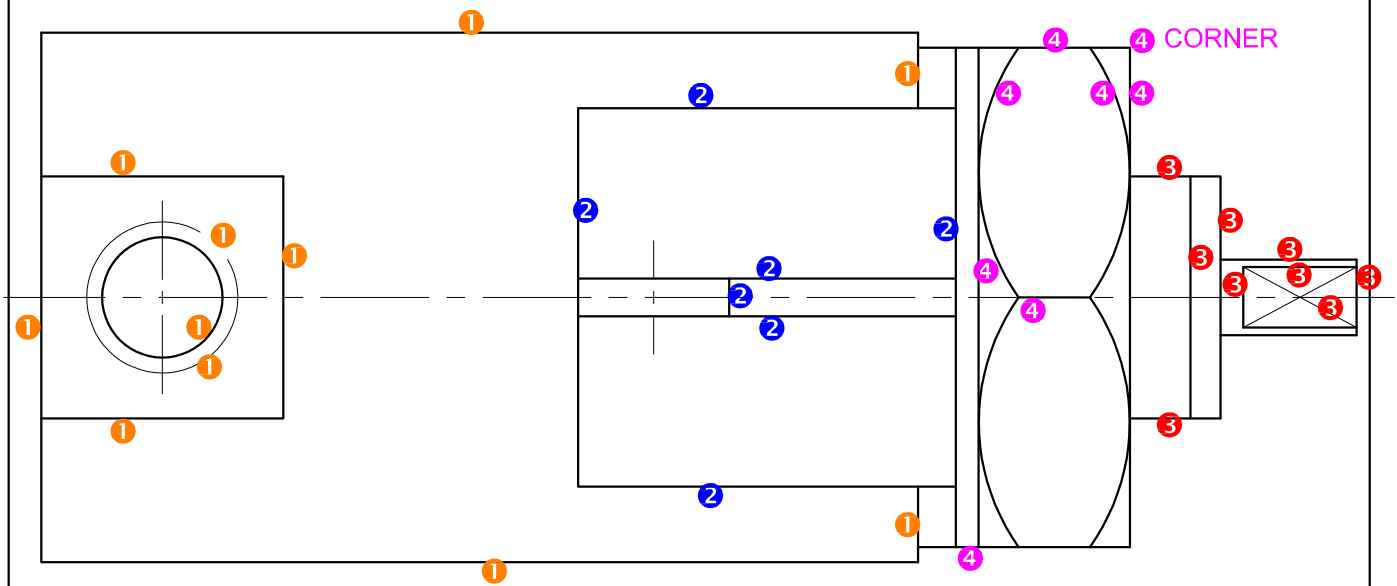

PAPER 2 QUESTION 4
 GRADE 12
 2021
 MARKING GUIDELINE

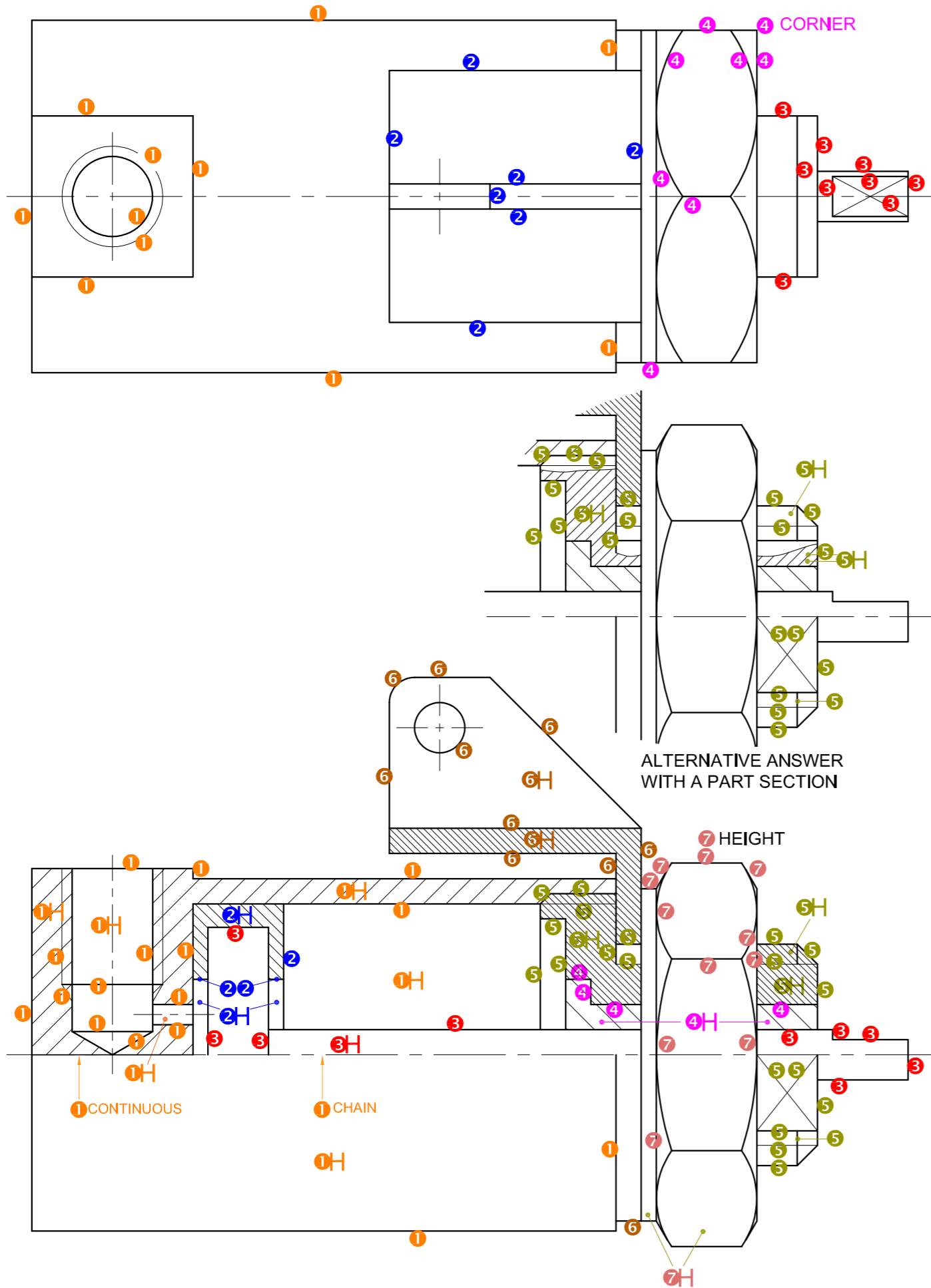

1. CENTRE LINE MARK ALLOCATION
 SANS COMPLIANT (LINE TYPE) 1
 7 CENTRE LINES (1-2=0, 3-5=1, 6-7=2) 2
TOTAL 3

2. ASSEMBLY
 1 MARK FOR EVERY
 COMPONENT CORRECTLY
 ASSEMBLED (9 PARTS -1) = 8

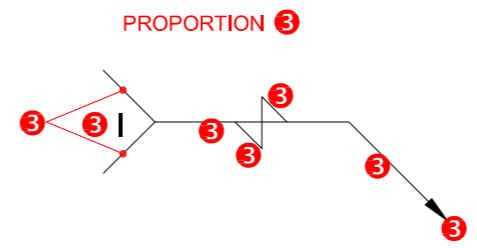

ALTERNATIVE ANSWER
 WITH A PART SECTION

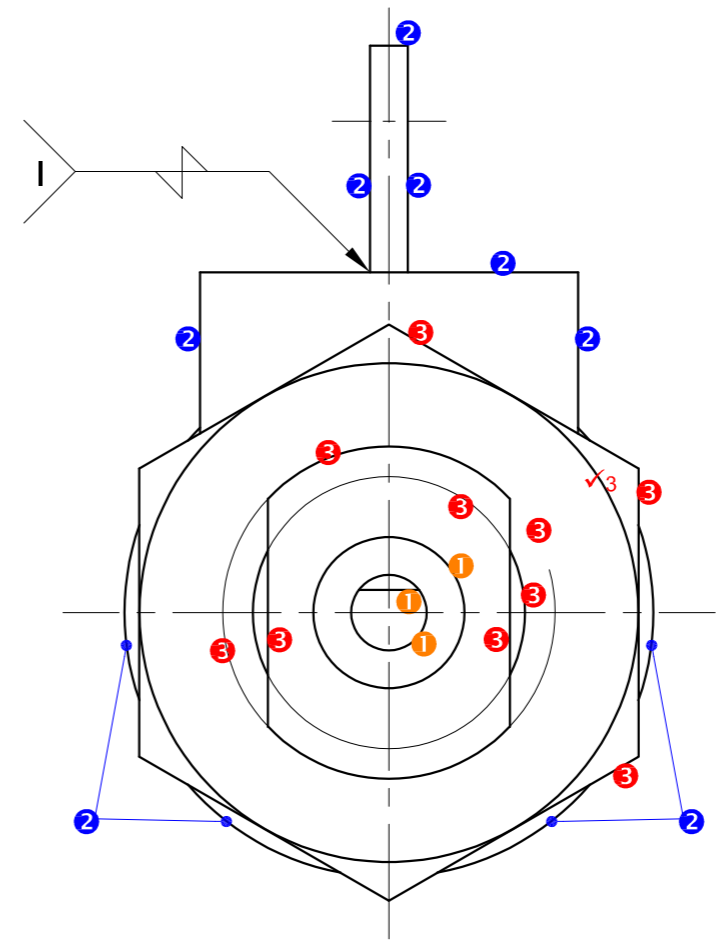

FOR OFFICIAL USE ONLY	
INCORRECT OVERALL SCALE	
INCORRECT HATCHING	
PARTS NOT ASSEMBLED	
TOTAL PENALTIES (-)	

ASSESSMENT CRITERIA					
RIGHT VIEW					
		POSSIBLE	OBTAINED	SIGN	MODERATED
1	SHAFT + BUSH	1 1/2			
2	CYLINDER + BRACKET + HOOK	4			
3	M44 NUT + GUIDE	6			
SUBTOTAL		11 1/2			
HALF-SECTIONAL FRONT VIEW					
1	CYLINDER	12			
2	RUBBER SEAL	2 1/2			
3	PLUNGER	5			
4	BUSH	2 1/2			
5	GUIDE	11 1/2			
6	BRACKET + HOOK	6			
7	M44 NUT + WASHER	6 1/2			
SUBTOTAL		46			
TOP VIEW					
1	CYLINDER	5 1/2			
2	BRACKET + HOOK	3 1/2			
3	GUIDE + SHAFT	4 1/2			
4	M44 NUT + WASHER	4			
SUBTOTAL		17 1/2			
GENERAL					
1	CENTRE LINES	3			
2	ASSEMBLY	8			
3	WELDING SYMBOL	4			
SUBTOTAL		15			
TOTAL		90			
PENALTIES (-)					
GRAND TOTAL					
EXAMINATION NUMBER					
EXAMINATION NUMBER					